

**JUKI®**

**HIGH-SPEED 1-NEEDLE NEEDLE-FEED LOCKSTITCH  
MACHINE WITH AUTOMATIC THREAD TRIMMER**

**DLN-5410N-7**

**INSTRUCTION MANUAL**

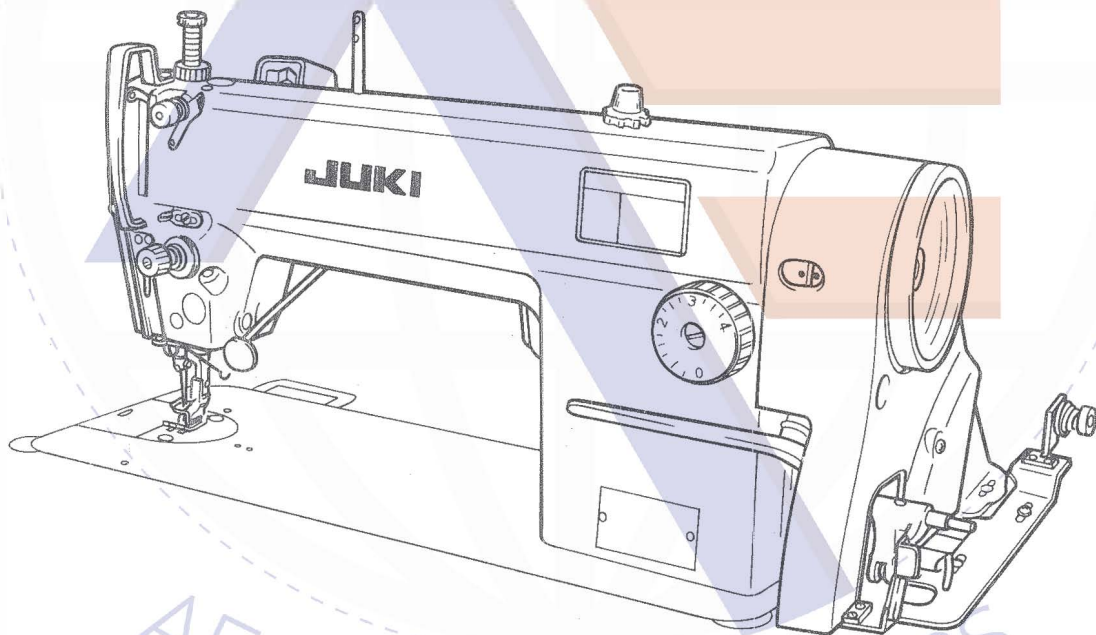

**NOTE:** Read safety instructions carefully and understand them before using your DLN-5410N-7.  
Retain this instruction Manual for future reference.

**No.03**

**29119203**

## IMPORTANT SAFETY INSTRUCTIONS

Congratulations on your purchase of a JUKI machine.

To get the most out of the many functions of this machine and operate it in safety, it is necessary to use this machine correctly.

Please read this Instruction Manual carefully before use. We hope you will enjoy the use of your machine for a long time. Please remember to keep this manual in a safe place.

1. Observe the basic safety measures, including, but not limited to the following ones, whenever you use the machine.
2. Read all the instructions, including, but not limited to this Instruction Manual before you use the machine. In addition, keep this Instruction Manual so that you may read it at anytime when necessary.
3. Use the machine after it has been ascertained that it conforms with safety rules/standards valid in your country.
4. All safety devices must be in position when the machine is ready for work or in operation. The operation without the specified safety devices is not allowed.
5. This machine shall be operated by appropriately-trained operators.
6. For your personal protection, we recommend that you wear safety glasses.
7. For the following, turn off the power switch or disconnect the power plug of the machine from the receptacle.
  - 7-1 For threading needle(s), looper, spreader etc. and replacing bobbin.
  - 7-2 For replacing part(s) of needle, presser foot, throat plate, looper, spreader, feed dog, needle guard, folder, cloth guide etc.
  - 7-3 For repair work.
  - 7-4 When leaving the working place or when the working place is unattended.
  - 7-5 When using clutch motors without applying brake, it has to be waited until the motor stopped totally.
8. If you should allow oil, grease, etc. used with the machine and devices to come in contact with your eyes or skin or swallow any of such liquid by mistake, immediately wash the contacted areas and consult a medical doctor.

9. Tampering with the live parts and devices, regardless of whether the machine is powered, is prohibited.
10. Repair, remodeling and adjustment works must only be done by appropriately trained technicians or specially skilled personnel. Only spare parts designated by JUKI can be used for repairs.
11. General maintenance and inspection works have to be done by appropriately trained personnel.
12. Repair and maintenance works of electrical components shall be conducted by qualified electric technicians or under the audit and guidance of specially skilled personnel.

Whenever you find a failure of any of electrical components, immediately stop the machine.
13. Before making repair and maintenance works on the machine equipped with pneumatic parts such as an air cylinder, the air compressor has to be detached from the machine and the compressed air supply has to be cut off. Existing residual air pressure after disconnecting the air compressor from the machine has to be expelled. Exceptions to this are only adjustments and performance checks done by appropriately trained technicians or specially skilled personnel.
14. Periodically clean the machine throughout the period of use.

15. Grounding the machine is always necessary for the normal operation of the machine. The machine has to be operated in an environment that is free from strong noise sources such as high-frequency welder.
16. An appropriate power plug has to be attached to the machine by electric technicians. Power plug has to be connected to a grounded receptacle.

17. The machine is only allowed to be used for the purpose intended. Other used are not allowed.
18. Remodel or modify the machine in accordance with the safety rules/standards while taking all the effective safety measures. JUKI assumes no responsibility for damage caused by remodeling or modification of the machine.

19. Warning hints are marked with the two shown symbols.



Danger of injury to operator or service staff



Items requiring special attention

## FOR SAFE OPERATION



1. To avoid electrical shock hazards, neither open the cover of the electrical box for the motor nor touch the components mounted inside the electrical box.



1. To avoid personal injury, never operate the machine with any of the belt cover, finger guard or safety devices removed.
2. To prevent possible personal injuries caused by being caught in the machine, keep your fingers, head and clothes away from the handwheel, V belt and the motor while the machine is operation. In addition, place nothing around them.
3. To avoid personal injury, never put your hand under the needle when you turn "ON" the power switch or operate the machine.
4. To avoid personal injury, never put your fingers into the thread take-up cover while the machine is in operation.
5. The hook rotates at a high speed while the machine is in operation. To prevent possible injury to hands, be sure to keep your hands away from the vicinity of the hook during operation. In addition, be sure to turn OFF the power to the machine when replacing the bobbin.
6. To avoid possible personal injuries, be careful not to allow your fingers in the machine when tilting/raising the machine head.
7. To avoid possible accidents because of abrupt start of the machine, turn OFF the power to the machine when tilting the machine head or removing the belt cover and the V belt.
8. If your machine is equipped with a servo-motor, the motor does not produce noise while the machine is at rest. To avoid possible accidents due to abrupt start of the machine, be sure to turn OFF the power to the machine.
9. To avoid electrical shock hazards, never operate the sewing machine with the ground wire for the power supply removed.
10. To prevent possible accidents because of electric shock or damaged electrical component(s), turn OFF the power switch in prior to the connection/disconnection of the power plug.

AE Sewing Machines

## CONTENTS

BEFORE OPERATION .....	1
1. INSTALLATION .....	1
2. LUBRICATION .....	2
3. ADJUSTING THE AMOUNT OF OIL (OIL SPLASHES) IN THE HOOK .....	2
4. ATTACHING THE NEEDLE .....	3
5. SETTING THE BOBBIN INTO THE BOBBIN CASE .....	3
6. THREADING THE MACHINE HEAD .....	4
7. ADJUSTING THE STITCH LENGTH .....	4
8. INSTALLING THE THREAD STAND .....	4
9. INSTALLING THE BELT COVER AND THE BOBBIN WINDER .....	5
10. ADJUSTING THE HEIGHT OF THE KNEE LIFTER .....	5
11. PEDAL OPERATION .....	5
12. THREAD TENSION .....	6
13. THREAD TAKE-UP SPRING .....	6
14. HAND LIFTER .....	6
15. PRESSER FOOT PRESSURE .....	6
16. ADJUSTING THE FEED TIMING .....	7
17. TILT OF THE FEED DOG .....	7
18. ADJUSTING STITCH WIDTH .....	7
19. HEIGHT OF THE FEED DOG .....	7
20. NEEDLE-TO-HOOK RELATIONSHIP .....	8
21. ADJUSTING THE HEIGHT OF THE PRESSER FOOT .....	8
22. COUNTER KNIFE .....	8
23. ADJUSTING THE THREAD TAKE-UP STROKE .....	9
24. ADJUSTING THE NEEDLE STOP POSITION .....	9
25. PEDAL PRESSURE AND PEDAL STROKE .....	9
26. ADJUSTMENT OF THE PEDAL .....	10
27. AUTOMATIC REVERSE FEED STITCHING .....	10
28. WIPER .....	10
29. SPECIFICATIONS .....	11

## BEFORE OPERATION



### CAUTION:

To avoid malfunction and damage of the machine, confirm the following.

- Before you put the machine into operation for the first time after the set-up, clean it thoroughly.
- Remove all dust gathering during transportation and oil it well.
- Confirm that the voltage has been correctly set.
- Confirm that the power plug has been properly connected to the power supply.
- Never use the machine in the state where the voltage type is different from the designated one.
- Confirm that the direction of rotation of the motor pulley is correct.

## 1. INSTALLATION

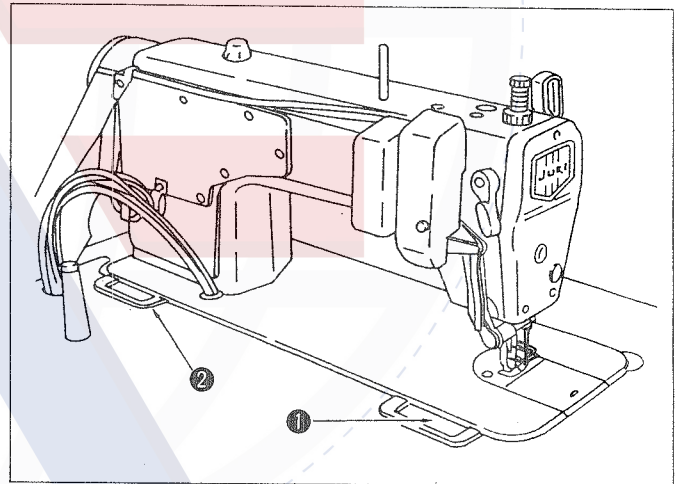
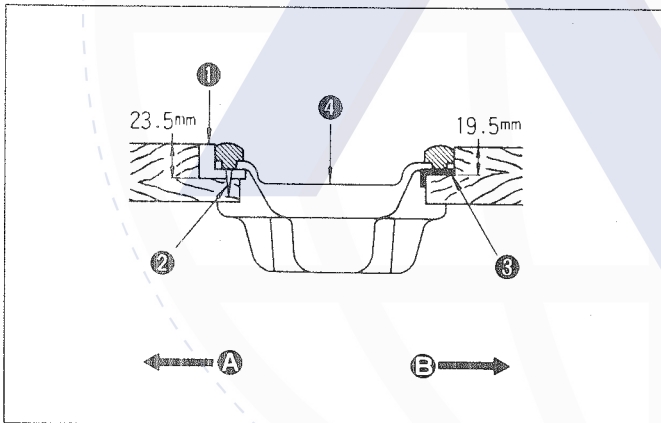
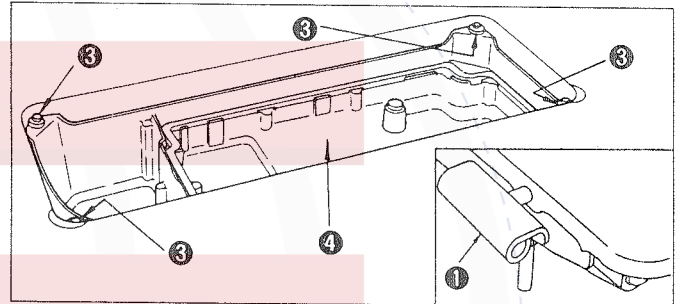
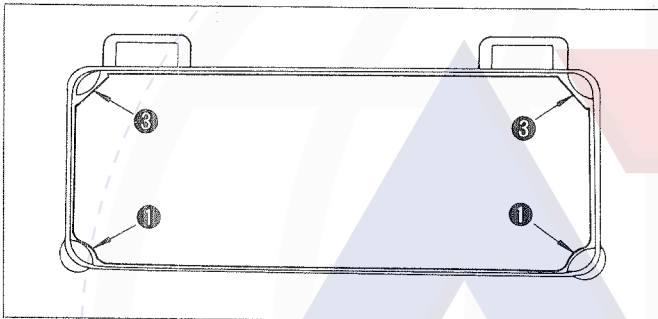

### 1. Installing the oil pan

- 1) The oil pan should rest on the four corners of the machine table groove.
  - 2) Two rubber seats ① for supporting the head portion on the operator side ④ are fixed on the extended portion of the table by hitting the nail ②, and the other two rubber cushion seats ③ on the hinge side ⑤ are fixed by using a rubber-based adhesive. Then, oil pan ④ is placed.
- 1) Fit hinge ① into the opening in the machine bed, and fit the machine head to table rubber hinge ② before placing the machine head on cushions ③ on the four corners.

## 2. LUBRICATION



### WARNING:

Turn OFF the power before starting the work so as to prevent accidents caused by abrupt start of the sewing machine.

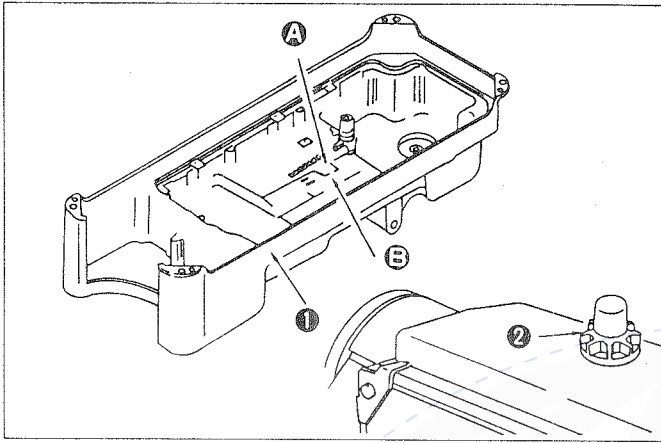

### 1. Information on lubrication

- 1) Fill oil pan ① with JUKI New Defrix Oil No. 1 up to HIGH mark ④.
- 2) When the oil level lowers below LOW mark ③, refill the oil pan with the specified oil.
- 3) When you operate the machine after lubrication, you will see splashing oil through oil sight window ② if the lubrication is adequate.
- 4) Note that the amount of the splashing oil is unrelated to the amount of the lubricating oil.

(Precaution) When you first operate your machine after setup or after an extended period of disuse, run your machine at 3,000s.p.m. to 3,500 s.p.m. for about 10 minutes for the purpose of break-in.

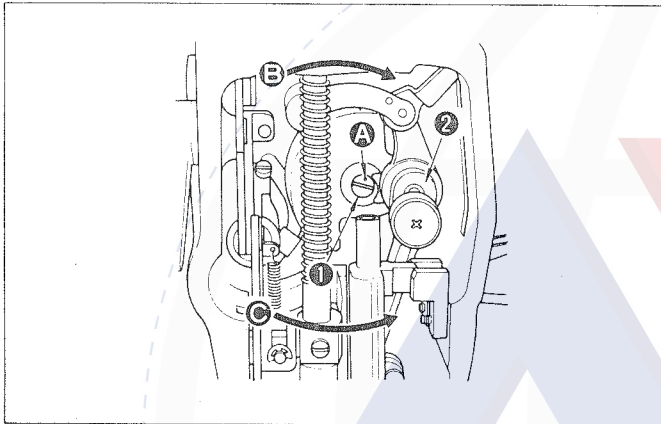

### WARNING:

Turn OFF the power before starting the work so as to prevent accidents caused by abrupt start of the sewing machine.

### 2. Adjusting the amount of oil supplied to the face plate parts

- 1) Adjust the amount of oil supplied to the thread take-up and needle bar crank ② by turning adjust pin ①.
- 2) The minimum amount of oil is reached when marker dot ④ is brought close to needle bar crank ② by turning the adjust pin in direction ⑤.
- 3) The maximum amount of oil is reached when marker dot ④ is brought to the position just opposite from the needle bar crank by turning the adjust pin in direction ⑥.

## 3. ADJUSTING THE AMOUNT OF OIL (OIL SPLASHES) IN THE HOOK



### WARNING:

Be extremely careful about the operation of the machine since the amount of oil has to be checked by turning the hook at a high speed.

① Amount of oil (oil splashes) confirmation paper



\* Use any paper available regardless of the material.

② Position to confirm the amount of oil (oil splashes)

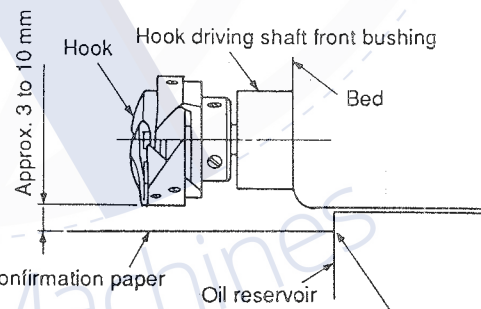

Closely fit the paper against the wall surface of the oil reservoir.

\* Place the amount of oil (oil splashes) confirmation paper under the hook.

\* When carrying out the procedure described below in 2, remove the slide plate and take extreme caution not to allow your fingers to come in contact with the hook.

- (Caution)
1. If the machine has not been sufficiently warmed up for operation make the machine run idle for approximately three minutes. (Moderate intermittent operation)
  2. Place the amount of oil (oil splashes) confirmation paper under the hook while the sewing machine is in operation.
  3. Confirm that the height of the oil surface in the oil reservoir is within the range between "HI" and "LOW".
  4. Confirmation of the amount of oil should be completed in five seconds. (Check the period of time with a watch.)

## ● Sample showing the appropriate amount of oil

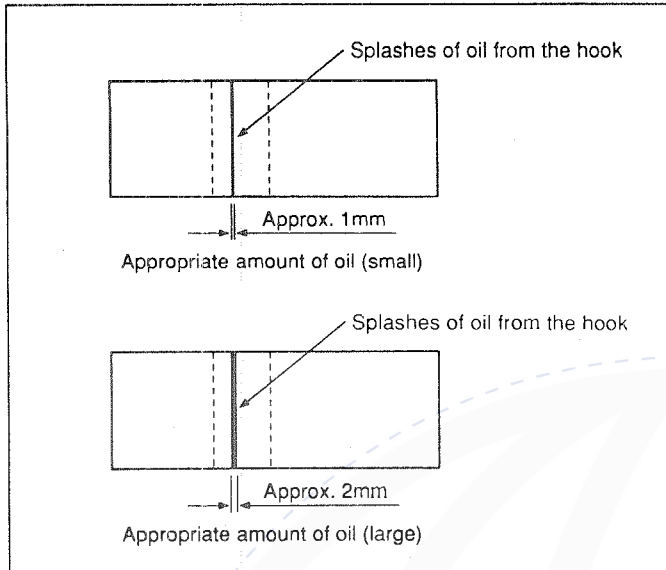

- 1) The amount of oil shown in the samples on the left should be finely adjusted in accordance with sewing processes. Be careful not to excessively increase/decrease the amount of oil in the hook. (If the amount of oil is too small, the hook will be seized (the hook will be hot). If the amount of oil is too much, the sewing product may be stained with oil.)
- 2) Adjust the amount of oil in the hook so that the oil amount (oil splashes) should not change while checking the oil amount three times (on the three sheets of paper).

## ● Adjusting the amount of oil (oil splashes) in the hook

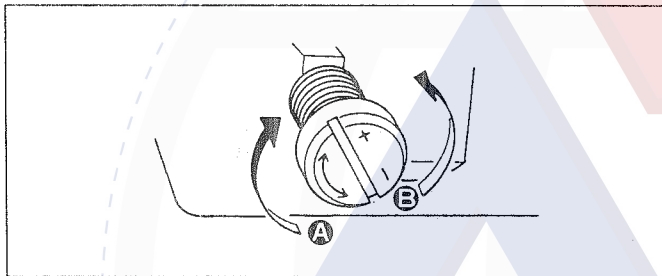

### WARNING:

Turn OFF the power before starting the work so as to prevent accidents caused by abrupt start of the sewing machine.

- 1) Turning the oil amount adjustment screw mounted on the hook driving shaft front bushing in the "+" direction (in direction **A**) will increase the amount of oil (oil splashes) in the hook, or in the "-" direction (in direction **B**) will decrease it.
- 2) After the amount of oil in the hook has been properly adjusted with the oil amount adjustment screw, make the sewing machine run idle for approximately 30 seconds to check the amount of oil (oil splashes) in the hook.

## 4. ATTACHING THE NEEDLE

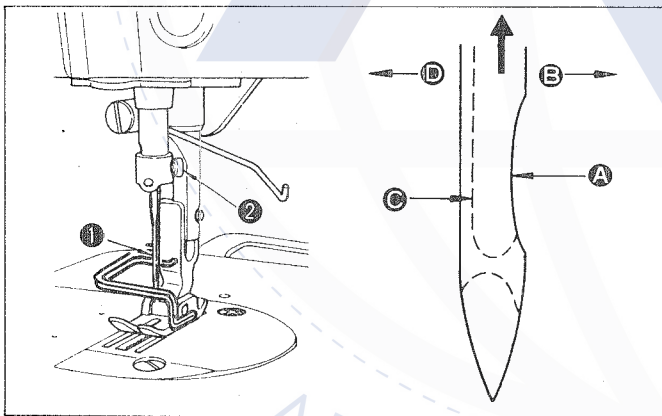

### WARNING:

Turn OFF the power before starting the work so as to prevent accidents caused by abrupt start of the sewing machine.

A needle of DB x 1 should be used. Select a proper needle size according to the count of thread and the type of material used.

- 1) Turn the handwheel until the needle bar reaches the highest point of its stroke.
- 2) Loosen screw **2**, and hold needle **1** with its indented part **A** facing exactly to the right in direction **B**.
- 3) Insert the needle fully into the hole in the needle bar in the direction of the arrow until the end of hole is reached.
- 4) Securely tighten screw **2**.
- 5) Check that long groove **C** of the needle is facing exactly to the left in direction **D**.

## 5. SETTING THE BOBBIN INTO THE BOBBIN CASE

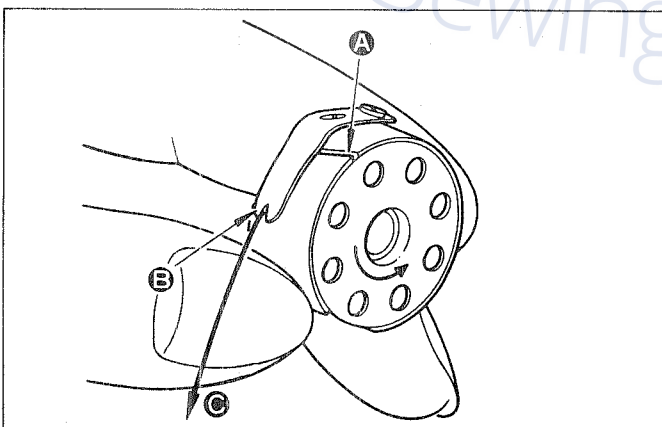

- 1) Install the bobbin in the bobbin case so that the thread wound direction is counterclockwise.
- 2) Pass the thread through thread slit **A**, and pull the thread in direction **B**. By so doing, the thread will pass under the tension spring and come out from notch **C**.
- 3) Check that the bobbin rotates in the direction of the arrow when thread **C** is pulled.

## 6. THREADING THE MACHINE HEAD



### WARNING:

Turn OFF the power before starting the work so as to prevent accidents caused by abrupt start of the sewing machine.

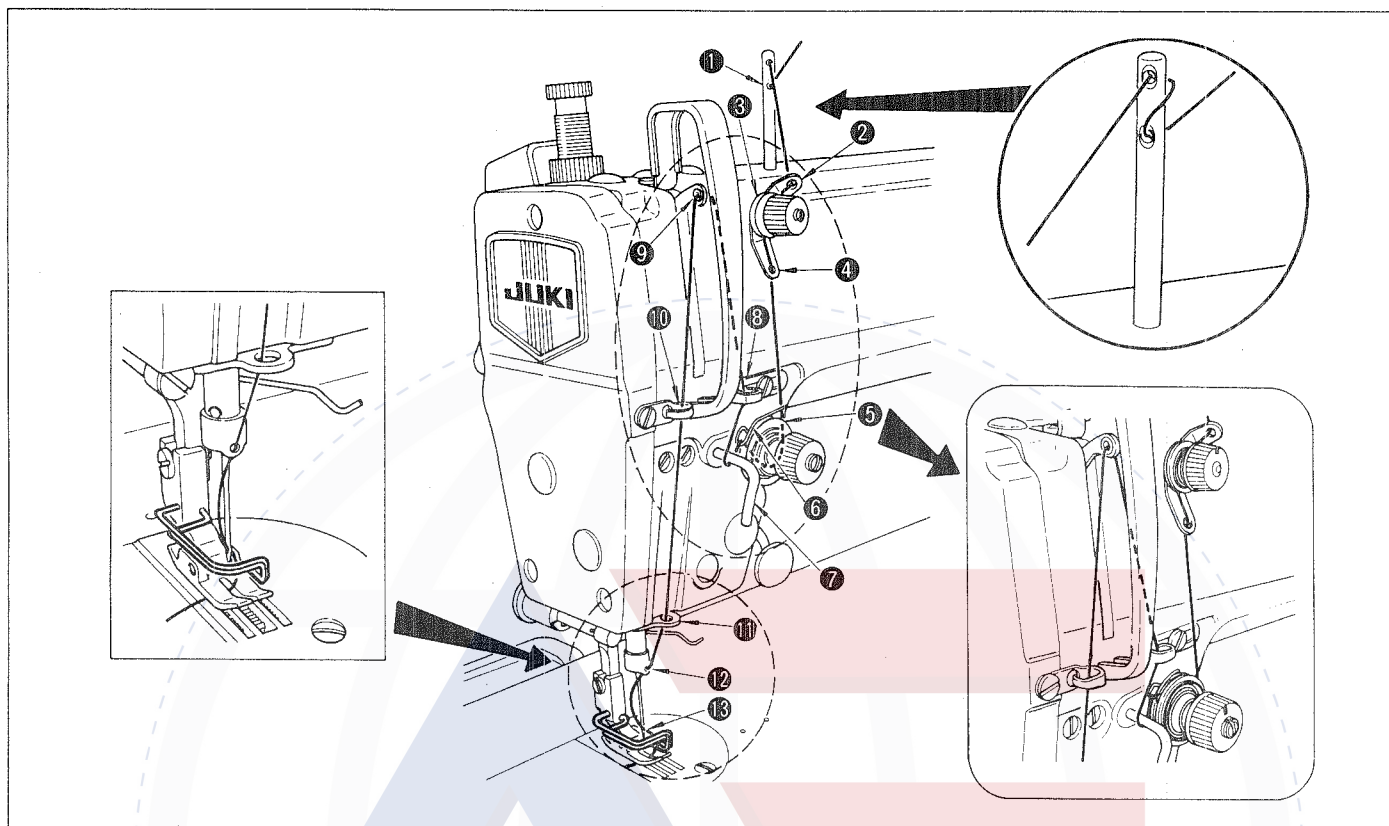

## 7. ADJUSTING THE STITCH LENGTH

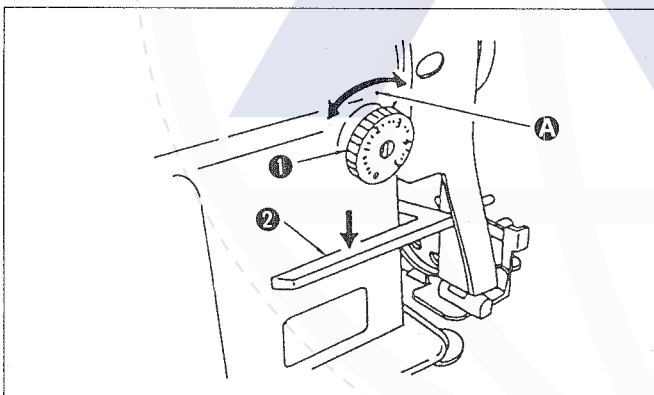

- 1) Turn stitch length dial ① in the direction of the arrow, and align the desired number to marker dot (A) on the machine arm.
- 2) The dial calibration is in millimeters.
- 3) When you want to decrease the stitch length, turn stitch length dial ① while pressing feed lever ② in the direction of the arrow.

## 8. INSTALLING THE THREAD STAND

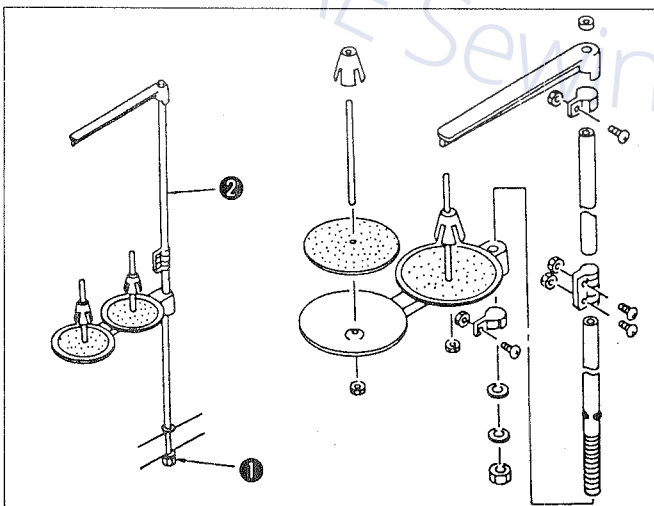

- 1) Assemble the thread stand unit, and insert it in the hole in the machine table.
- 2) Tighten locknut ① to fix the thread stand.
- 3) For ceiling wiring, pass the power cord through spool rest rod ②.



## 9. INSTALLING THE BELT COVER AND THE BOBBIN WINDER

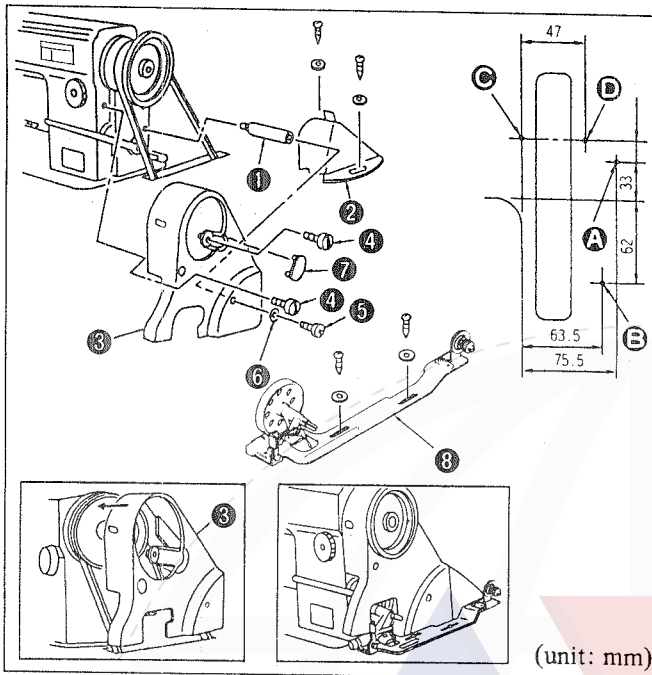

### WARNING:

Turn OFF the power before starting the work so as to prevent accidents caused by abrupt start of the sewing machine.

### 1. Installation procedure

- 1) Drill four guiding holes (A), (B), (C) and (D) for wooden screws in the table.
- 2) Install belt cover support (1) in the tapped hole in the arm.
- 3) Pass the handwheel through the hole in belt cover A (3), then set the handwheel on the arm. At this time, you can smoothly install the handwheel diagonally from the rear of the handwheel by tilting belt cover A (3) as illustrated in the figure.
- 4) Place belt cover B (2) on guiding holes (C) and (D).
- 5) Fix belt cover A (3) on the arm using screws (4), (5) and washer (6). At this time, tighten screw (4) with a tightening torque of 30 kgf/cm and screw (5) with a tightening torque of 25 kgf/cm. If you tighten further these screws, the securing state of the belt cover will not change.
- 6) Fit cat (7) to the belt cover A.
- 7) Move belt cover B (2) backward until the rubber section of belt cover B (2) comes in contact with belt cover A (3). Then, further move the belt cover B in the same direction by 0.5 to 1 mm. Now, fix the belt cover B in position using wooden screw and washer.
- 8) Fix bobbin winder (8) in guiding holes (A) and (B) using wooden screws and washers.

## 10. ADJUSTING THE HEIGHT OF THE KNEE LIFTER

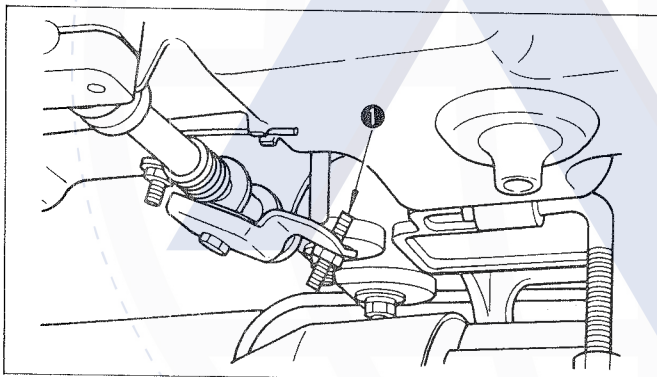

### WARNING:

Turn OFF the power before starting the work so as to prevent accidents caused by abrupt start of the sewing machine.

- 1) The standard height of the presser foot lifted using the knee lifter is 10 mm.
- 2) You can adjust the presser foot lift up to 13 mm using knee lifter adjust screw (1).
- 3) When you have adjusted the presser foot lift to over 10 mm, be sure that the bottom end of needle bar (2) in its lowest position does not hit presser foot (3).

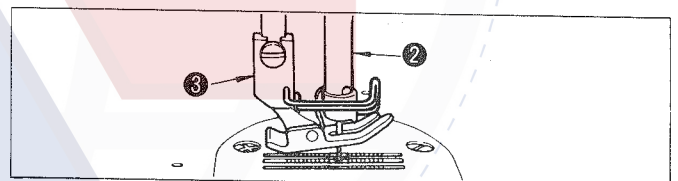

## 11. PEDAL OPERATION

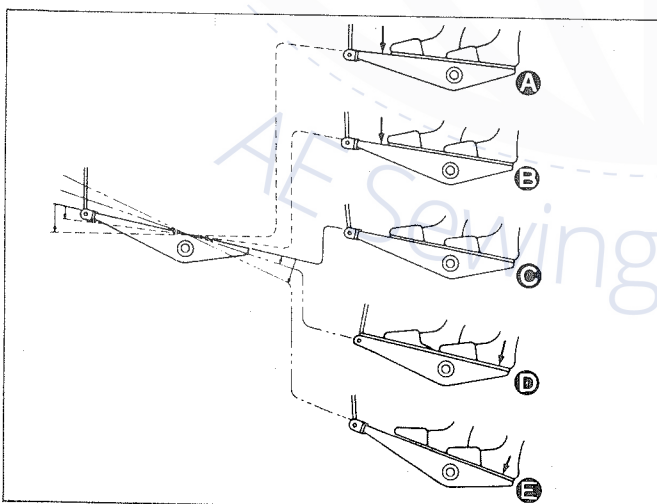

### 1. The pedal is operated in the following 4 steps:

- 1) The machine runs at low sewing speed when you lightly depress the front part of the pedal. (B)
  - 2) The machine runs at high sewing speed when you further depress the front part of the pedal. (A) (If the automatic reverse feed stitching has been preset, the machine runs at high speed after it completes reverse feed stitching.)
  - 3) The machine stops (with its needle up or down) when you reset the pedal to its original position. (C)
  - 4) The machine trims threads when you fully depress the back part of the pedal. (D)
- \* If your machine is provided with the Auto-lifter (AK Series), an addition step is given between the machine stop and thread trimming step.  
The presser foot goes up when you lightly depress the back part of the pedal (D), and if you further depress the back part, the thread trimmer is actuated.
- If you reset the pedal to its neutral position during the automatic reverse feed stitching at seam start, the machine stops after it completes the reverse feed stitching.
  - The machine will perform normal thread trimming even if you depress the back part of the pedal immediately following high or low speed sewing.

- The machine will completely perform thread trimming even if you reset the pedal to its neutral position immediately after the machine started thread trimming action.
- When the machine stops with its needle down, and if you want to bring the needle up, depress the back part of the pedal once.

## 12. THREAD TENSION

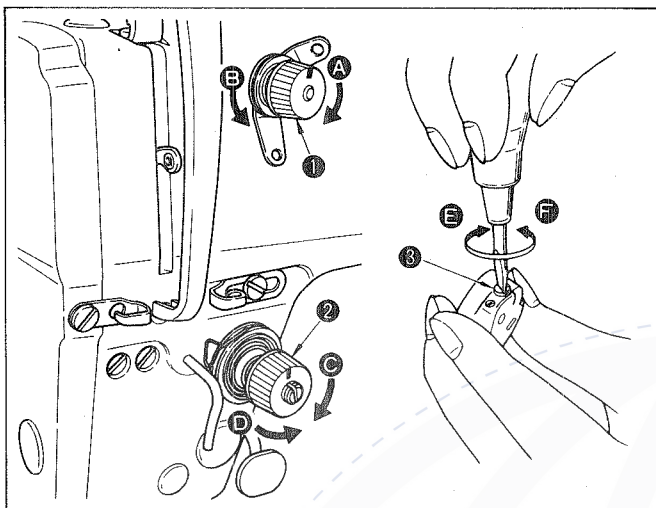

### 1. Adjusting the needle thread tension

- 1) As you turn thread tension No. 1 nut ① clockwise (in direction A), the thread remaining on the needle after thread trimming will be shorter.
- 2) As you turn nut ① counterclockwise (in direction B), the thread length will be longer.
- 3) As you turn thread tension nut ② clockwise (in direction C), the needle thread tension will be increased.
- 4) As you turn nut ② counterclockwise (in direction D), the needle thread tension will be decreased.

### 2. Adjusting the bobbin thread tension

- 1) As you turn tension adjust screw ③ clockwise (in direction E), the bobbin thread tension will be increased.
- 2) As you turn screw ③ counterclockwise (in direction F), the bobbin thread tension will be decreased.

## 13. THREAD TAKE-UP SPRING

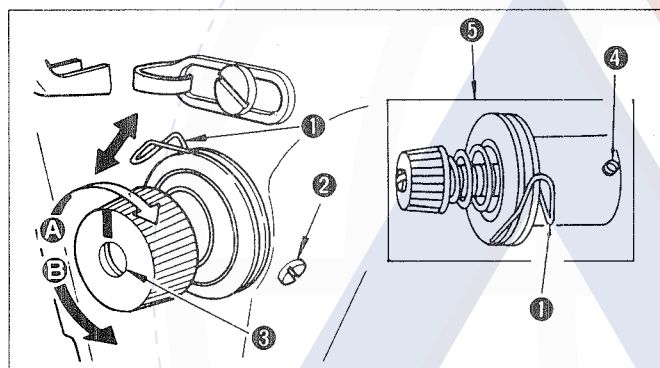

### 1. Changing the stroke of thread take-up spring ①

- 1) Loosen setscrew ②.
- 2) As you turn tension post ③ clockwise (in direction A), the stroke of the thread take-up spring will be increased.
- 3) As you turn the knob counterclockwise (in direction B), the stroke will be decreased.

### 2. Changing the pressure of thread take-up spring ①

- 1) Loosen setscrew ②, and remove thread tension controller asm. ⑤.
- 2) Loosen setscrew ④.
- 3) As you turn tension post ③ clockwise (in direction A), the pressure will be increased.
- 4) As you turn the post counterclockwise (in direction B), the pressure will be decreased.

## 14. HAND LIFTER

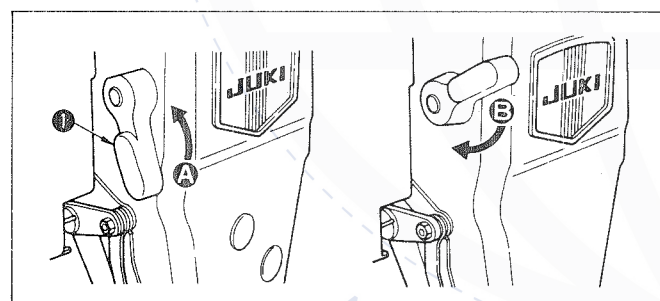

- 1) To stop the machine with its presser foot up, turn hand lifter lever ① in direction A.
- 2) The presser foot will go up about 5.5 mm and stop. The presser foot will go back to its original position when hand lifter lever is turned down in direction B.
- 3) Using the knee lifter, you can get the standard presser foot lift of about 10 mm and the maximum lift of about 13 mm.

## 15. PRESSER FOOT PRESSURE

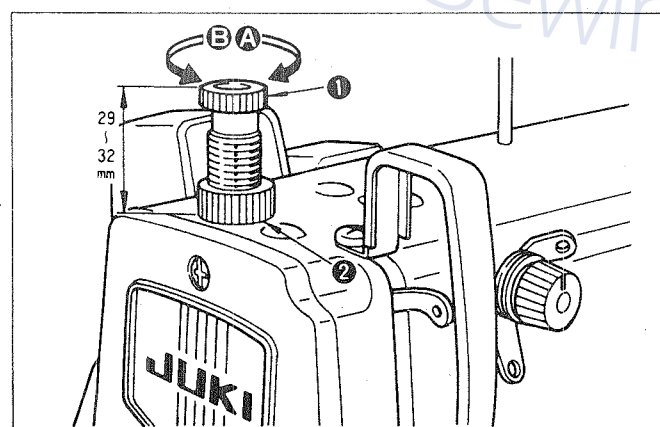

### WARNING:

Turn OFF the power before starting the work so as to prevent accidents caused by abrupt start of the sewing machine.

- 1) Loosen nut ②. As you turn presser spring regulator ① clockwise (in direction A), the presser foot pressure will be increased.
- 2) As you turn the presser spring regulator counterclockwise (in direction B), the pressure will be decreased.
- 3) After adjustment, tighten nut ②.
- 4) For general fabrics, the standard height of the presser spring regulator is 29 to 32 mm.

## 16. ADJUSTING THE FEED TIMING

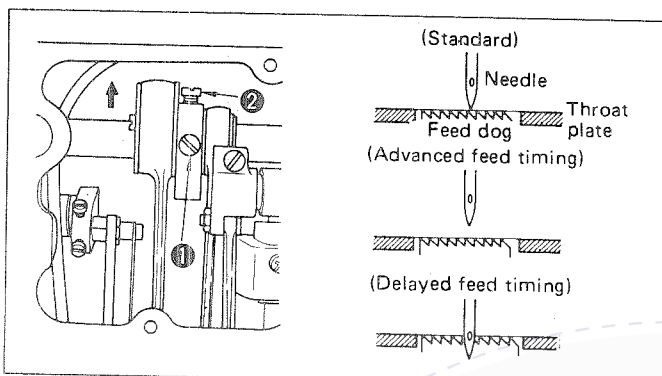

### WARNING:

Turn OFF the power before starting the work so as to prevent accidents caused by abrupt start of the sewing machine.

- 1) Set the feed adjusting dial at 0 on the scale.
- 2) For standard feed, loosen setscrew ① and ②, align the tip of the needle and the top surface of the feed dog with the top surface of the throat plate when the feed dog rises above the throat plate. Then, tighten the setscrews securely.
- 3) To make the cloth feed action faster, travel feed eccentric cam to the direction of the arrow.
- 4) To make the cloth feed action slower, travel feed eccentric cam to the opposite direction of the arrow.



### CAUTION:

Too much travel of the feed eccentric cam might cause a needle breakage.

## 17. TILT OF THE FEED DOG

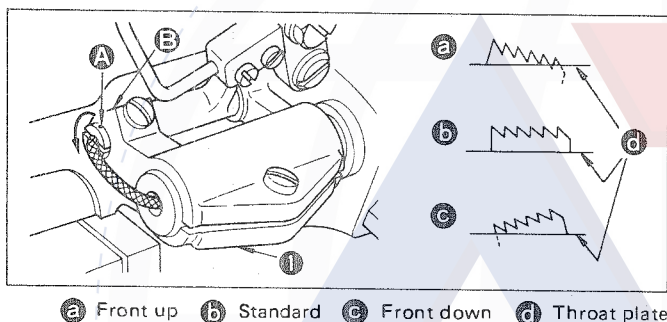

### WARNING:

Turn OFF the power before starting the work so as to prevent accidents caused by abrupt start of the sewing machine.

- 1) The standard tilt (horizontal) of the feed dog is obtained when marker dot A on the feed bar shaft is aligned with marker dot E on feed rocker ①.
- 2) To tilt the feed dog with its front up in order to prevent puckering, loosen the setscrew, and turn the feed bar shaft 90° in the direction of the arrow, using a screwdriver.
- 3) To tilt the feed dog with its front down in order to prevent uneven material feed, turn the feed bar shaft 90° in the opposite direction from the arrow.

(Precaution) Whenever the feed dog tilt is adjusted, the feed dog height will be changed. So, it is necessary to check the height after tilt adjustment.

## 18. ADJUSTING STITCH WIDTH

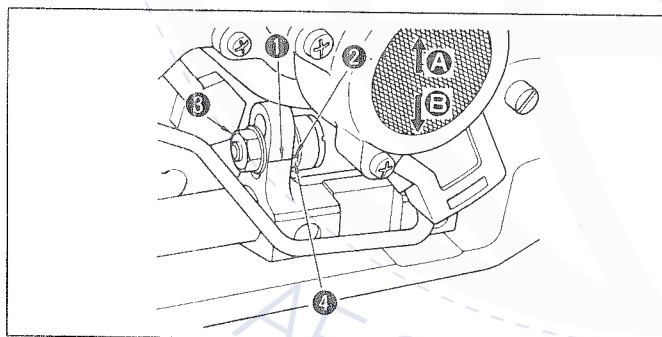

### WARNING:

Turn OFF the power before starting the work so as to prevent accidents caused by abrupt start of the sewing machine.

- 1) The standard stitch width is obtained when marker line ① of the feed rocker shaft crank align with marker line ② of needle feed rod shaft.
- 2) When it is required to make the needle feed amount larger than the feed dog amount, loosen locknut ③, move needle feed rod shaft ④ to the direction A, and tighten locknut ③.
- 3) On the contrary, moving needle feed rod shaft ④ to the direction B, the needle feed amount will be smaller than the feed dog amount.

(Note) Excessive adjustment of the stitch width might cause a needle breakage or other undesirable results.

## 19. HEIGHT OF THE FEED DOG

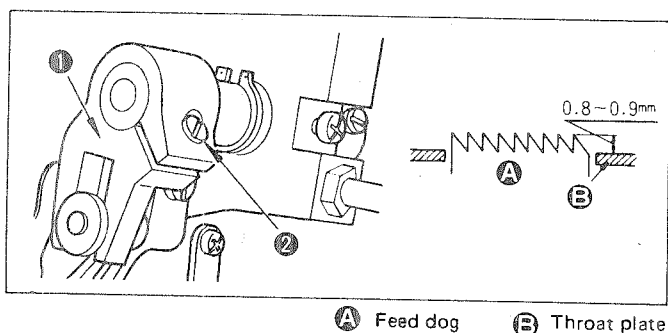

### WARNING:

Turn OFF the power before starting the work so as to prevent accidents caused by abrupt start of the sewing machine.

- 1) The protruding amount of feed dog A from throat plate B is factory-adjusted at 0.8 mm to 0.9 mm. (0.95 to 1.05 mm for DLN-5410NH-7)
- 2) If the feed dog juts out too much, puckering may result when sewing light-weight materials. (Recommended protrusion: 0.7 mm to 0.8 mm)
- 3) To adjust the height of the feed dog:
  - ① Loosen screw ② of forked link ①.
  - ② Move the feed bar up or down to make adjustment.
  - ③ Securely tighten screw ②.

(Caution) If the clamping pressure is insufficient, the forked portion will wear out.

## 20. NEEDLE-TO-HOOK RELATIONSHIP

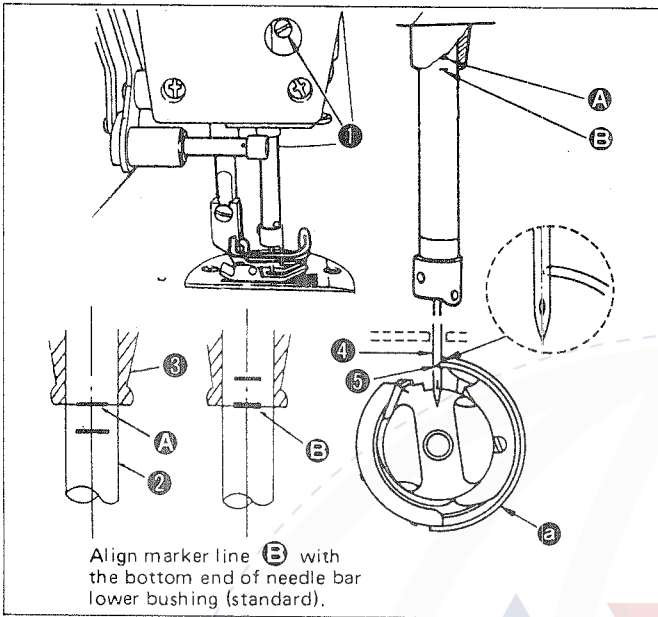

### WARNING:

Turn OFF the power before starting the work so as to prevent accidents caused by abrupt start of the sewing machine.

#### 1. Adjust the timing between the needle and the hook as follows:

- 1) Rotate the handwheel until the needle bar comes down to its lowest position, and loosen screw ①. Be sure to set feed adjusting dial at 0 on the scale.

(Adjusting the needle bar height)

- 2) Align marker line ① on needle bar ② with the bottom end of needle bar lower bushing ③, then tighten setscrew ①.

(Adjusting position of the hook ④)

- 3) Loosen the three hook setscrews, turn the handwheel, and align marker line ⑤ on ascending needle bar ② with the bottom end of needle bar lower bushing ③.

- 4) After making the adjustments mentioned in the above steps, align hook blade point ⑥ with the center of needle ④. Provide a clearance of 0.06 mm to 0.1 mm (reference value) between the needle and the hook, then securely tighten setscrews in the hook.

(Caution) If the clearance between the blade point of hook and the needle is smaller than the specified value, the blade point of hook will be damaged. If the clearance is larger, stitch skipping will result.

- The DLN-5410-7NH-7 model of sewing machine incorporates the hook of which part No.11321452. So use a hook of the same part No. when replacing your hook with a new one.

## 21. ADJUSTING THE HEIGHT OF THE PRESSER FOOT

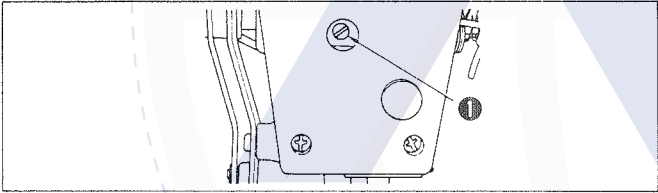

### WARNING:

Turn OFF the power before starting the work so as to prevent accidents caused by abrupt start of the sewing machine.

- 1) Loosen setscrew ①, and adjust the presser foot height and the angle of the presser foot.
- 2) After adjustment, securely tighten the setscrew ①.

## 22. COUNTER KNIFE

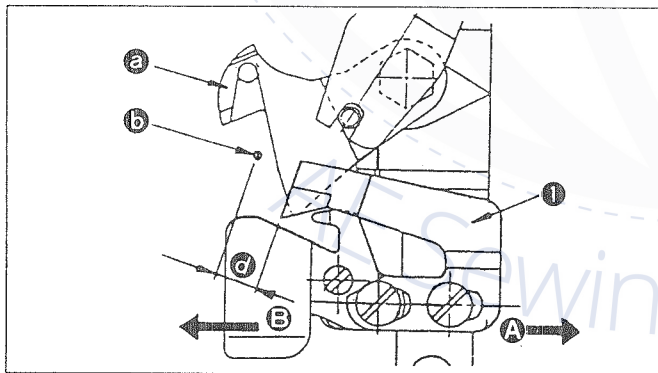

DLN-5410NH-7



### WARNING:

Turn OFF the power before starting the work so as to prevent accidents caused by abrupt start of the sewing machine.

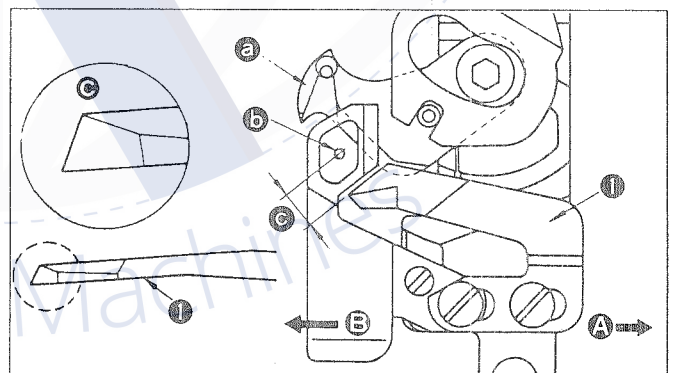

DLN-5410N-7

1. When the knife sharpness has deteriorated, sharpen counter knife ① as illustrated in ②, and properly reinstall it.

- 1) If the mounting position of the counter knife is moved in direction ① from the standard mounting position, the thread length after thread trimming will be increased accordingly.
- 2) If the mounting position of the counter knife is moved in direction ②, the thread length will be decreased accordingly.

② Moving knife    ③ Center of needle    ④ Standard: 4.0 mm (DLN-5410N-7)    ⑤ Standard: 4.5 mm

(Caution) When re-sharpening the knife blade, extra special care must be taken on the handling of the knife.

## 23. ADJUSTING THE THREAD TAKE-UP STROKE

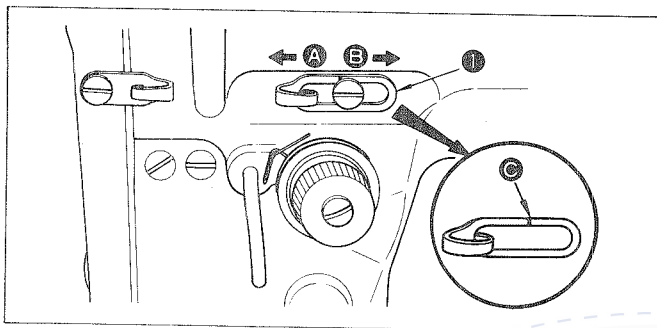

### WARNING:

Turn OFF the power before starting the work so as to prevent accidents caused by abrupt start of the sewing machine.

- 1) When sewing heavy-weight materials, move thread guide ① to the left in direction ④ to increase the length of thread pulled out by the thread take-up.
- 2) When sewing light-weight materials, move thread guide ① to the right in direction ⑤ to decrease the length of thread pulled out by the thread take-up.
- 3) The standard position of take-up thread guide ① is obtained when marker line ③ is positioning approx. 1 mm away from the center of the screw to the left direction.

## 24. ADJUSTING THE NEEDLE STOP POSITION



### WARNING:

Turn OFF the power before starting the work so as to prevent accidents caused by abrupt start of the sewing machine.

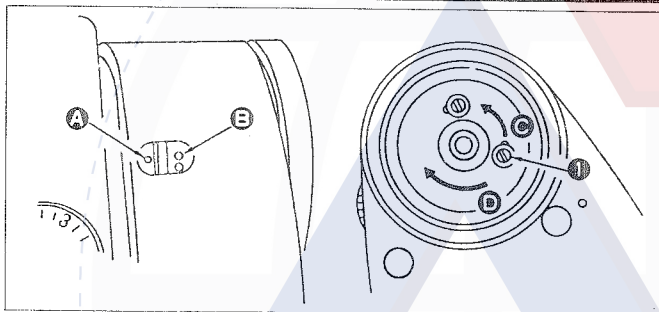

### 1. Stop position after thread trimming

- 1) The standard needle stop position is obtained by aligning marker dot ④ on the machine arm with white marker dot ⑤ on the handwheel.
- 2) Stop the needle in its highest position, loosen screw ① to perform adjustment within the slot of the screw.
  - ① The needle stop timing is advanced if you move the screw in direction ③.
  - ② The needle stop timing is delayed if you move the screw in direction ④.



### CAUTION:

Do not operate the machine with screw ① loosened. Just loosen the screw, and do not remove it.

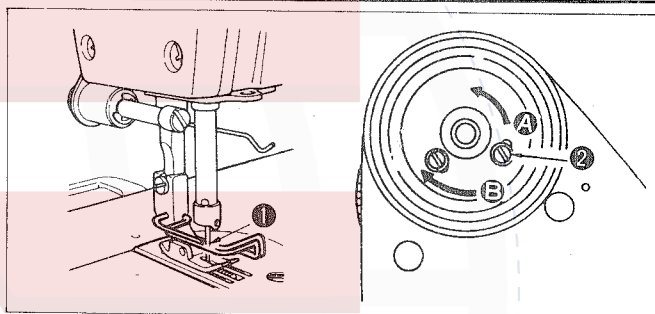

### 1. Lower stop position

- 1) The lower needle stop position when the pedal is returned to the neutral position after the front part of the pedal is depressed can be adjusted as follows: Stop needle ① in its lowest position, loosen screw ②, and make adjustment within the slot of the screw. Moving the screw in direction ④ advances the needle stop timing. Moving the screw in direction ⑤ delays the timing.



### CAUTION:

Do not operate the machine with screw ② loosened. Just loosen the screw, and do not remove it.

## 25. PEDAL PRESSURE AND PEDAL STROKE

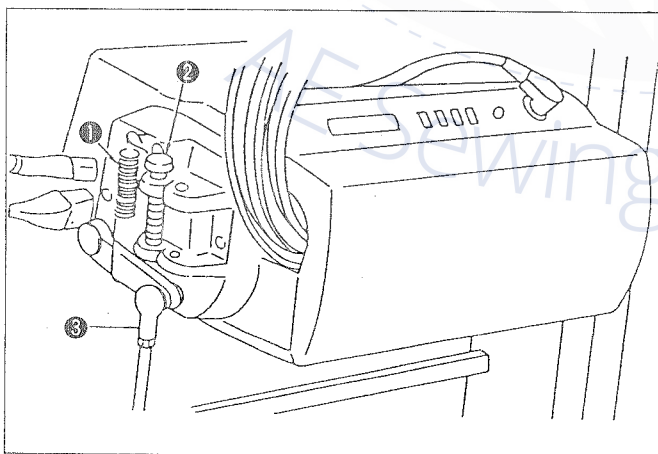

### WARNING:

Turn OFF the power before starting the work so as to prevent accidents caused by abrupt start of the sewing machine.

### 1. Adjusting the pressure required to depress the front part of the pedal

- 1) This pressure can be changed by altering the mounting position of pedaling pressure adjust spring ①.
- 2) The pressure decreases when you hook the spring on the left side.
- 3) The pressure increases when you hook the spring on the right side.

### 2. Adjusting the pressure required to depress the back part of the pedal

- 1) This pressure can be adjusted using regulator screw ②.
- 2) The pressure increases as you turn the regulator screw in.
- 3) The pressure decreases as you turn the screw out.

### 3. Adjusting the pedal stroke

- 1) The pedal stroke decreases when you insert connecting rod ③ into the left hole.

## 26. ADJUSTMENT OF THE PEDAL

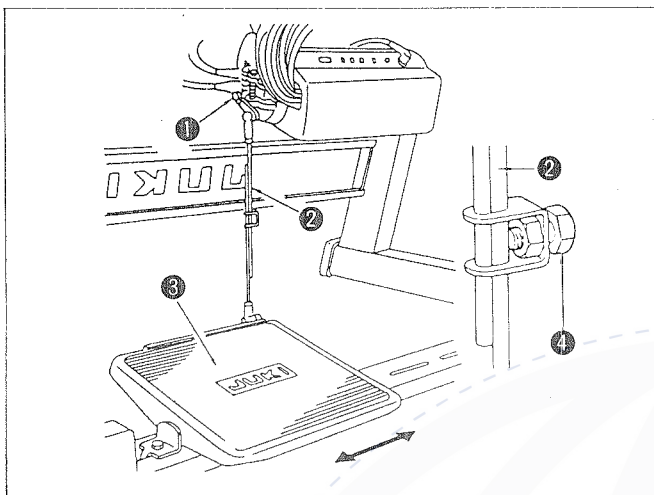

### WARNING:

Turn OFF the power before starting the work so as to prevent accidents caused by abrupt start of the sewing machine.

#### 1. Installing the connecting rod

- 1) Move pedal ③ to the right or left as illustrated by the arrows so that motor control lever ① and connecting rod ② are straightened.

#### 2. Adjusting the pedal angle

- 1) The pedal tilt can be freely adjusted by changing the length of the connecting rod.
- 2) Loosen adjust screw ④, and adjust the length of connecting rod ②.

## 27. AUTOMATIC REVERSE FEED STITCHING

(DLN-5410N-7-0B, DLN-5410N-7-WB, DLN-5410NH-7-0B, DLN-5410NH-7-WB)

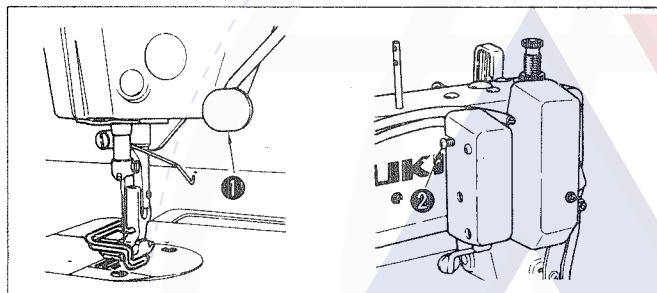

#### 1. How to operate

- 1) The moment switch lever ① is pressed, the machine performs reverse feed stitching.
- 2) The machine performs reverse feed stitching as long as the switch lever is held depressed.
- 3) The machine resumes normal feed stitching the moment the switch lever is released.



### WARNING:

Turn OFF the power before starting the work so as to prevent accidents caused by abrupt start of the sewing machine.

#### 2. Height of the switch lever

- 1) Adjust the height of switch lever ① so that it can be easily operated.
- 2) Loosen screw ②, and move the switch lever up or down to adjust its height.

## 28. WIPER (DLN-5410N-7-W0, DLN-5410N-7-WB, DLN-5410NH-7-W0, DLN-5410NH-7-WB)

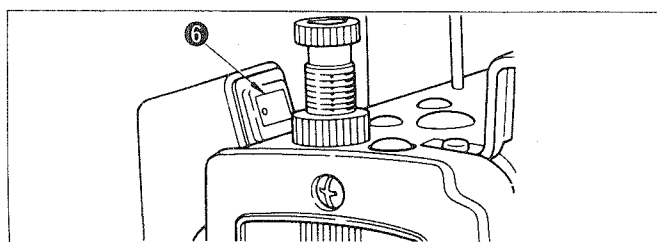
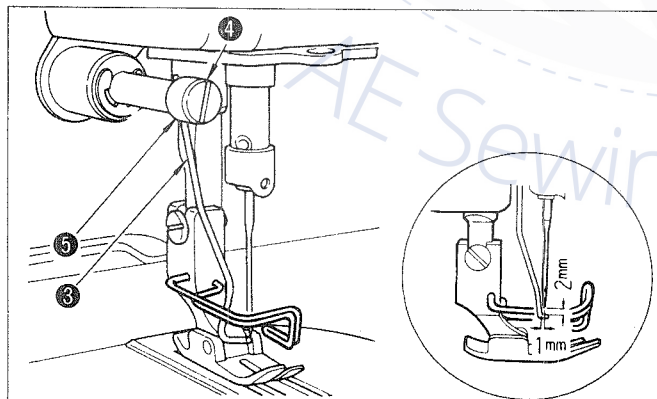
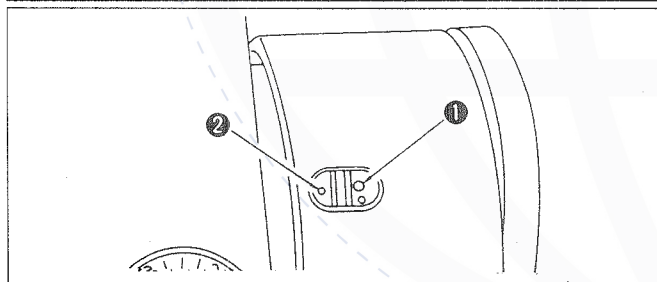

### WARNING:

Turn OFF the power before starting the work so as to prevent accidents caused by abrupt start of the sewing machine.

#### 1. Positioning the wiper

Adjust the position of the wiper according to the thickness of the material sewn. The adjustment procedure is as follows:

- 1) Turn the handwheel in the normal direction of rotation to align white marker dot ① on the handwheel with marker dot ② on the machine arm.
- 2) Adjust the distance between the flat part of the wiper ③ and the center of the needle to 1 mm. Tighten wiper adjust screw ④ so that the wiper ③ is pressed and fixed by wiper collar ⑤.
- 3) When the wiper is unnecessary, turn wiper sec saw switch ⑥ OFF.

## 29. SPECIFICATIONS

	DLN-5410N-7	DLN-5410NH-7
Application	General fabrics, light-to medium-weight materials	Medium- to heavy-weight materials
Sewing speed	Max. 5,000 s.p.m.	Max. 4,000 s.p.m.
Stitch length (max.)	4 mm	4.5 mm
Needle	DB x 1 #9 to #18	DB x 1 #20 to #22
Presser foot lift (by kenn lifter)	10 mm (standard) 13 mm (max.)	
Lubricating oil	JUKI New Defrix Oil No.1	





**JUKI®**

**JUKI CORPORATION**

INTERNATIONAL SALES DIVISION  
8-2-1, KOKURYO-CHO.  
CHOFU-SHI, TOKYO 182, JAPAN  
PHONE : 03(3430)4001~5  
FAX : 03(3430)4909 • 4914 • 4984  
TELEX : J22967

To order or for further information, please contact :

Please do not hesitate to contact our distributors or agents in your area for further information when necessary.  
**\* The description covered in this instruction manual is subject to change for improvement of the commodity without notice.**